

MINTA
Single-lever sink mixer 1/2"
MODEL # 32319

Pure Freude an Wasser

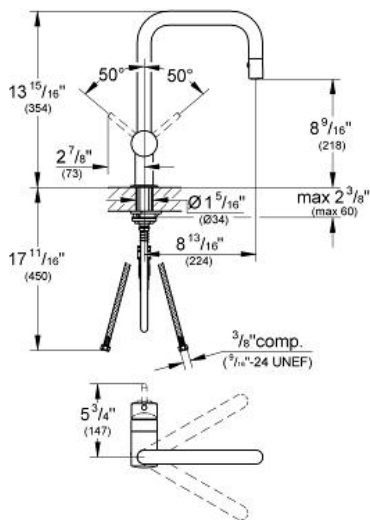

GROHE America, Inc | 200 North Gary Avenue, Suite G, Roselle, IL 60172
Phone: +1 (800) 444-7643 | Fax: +1 (800) 225-2778 | us-customerservice@grohe.com



Product Description:
Single-lever sink mixer 1/2"

Standard Specification:

- Dual Spray Pull-Out
- Single hole installation
- GROHE SilkMove® ceramic cartridge
- Adjustable flow rate limiter
- Swivel Spout
- Extractable integrated trigger spray
- Automatic returning
- Integrated non-return valve
- SpeedClean® anti-lime system
- Stainless Steel Braided Flexible Supplies
- Quick installation system
- Single Lever Handle
- Variable Handle Positioning
- Spout Reach 8 9/16"
- Protected against backflow
- Max Flow Rate: 1.75 gpm (6.6 L/min)

Applicable Codes & Standards:

- Energy Policy Act of 1992
- NSF 61
- ASME A112.18.1/CSA B125.1
- US Federal and State material regulations
- ICC/ANSI A117.1
- CalGreen

Color:

- 32319 000 chrome
- 32319 00E chrome
- 32319 DC0 supersteel
- 32319 DCE supersteel

